



GF Series 60" Raised Griddle/Broiler Gas Range

Item: _____
 Quantity: _____
 Project: _____
 Approval: _____
 Date: _____

GF Series 60" Raised Griddle/Broiler Gas Range

Models:

- GF60-6R24RR GFE60-6R24RR GF60-6R24RS GFE60-6R24RS



Model GF60-R24RR

NOTE: Ranges supplied with casters must be installed with an approved restraining device.

Standard Features:

- Flame failure protection: all burners
- Spark ignition on all concealed burners (open top burners manual ignition)
- Large 27" (686mm) work top surface
- Stainless steel front and sides
- Stainless steel 5" (127mm) plate rail
- Stainless steel low profile back guard
- 6" (152mm) adj. stainless steel legs
- Large easy-to-use control knobs
- Gas regulator 1" NPT rear gas connection
- 12" (305mm) section stamped drip trays w/ dimpled bottom
- Electric spark ignition on all burners, requiring single phase 115V 60Hz or 240V 50Hz (specify) prefix GFE models
- Ergonomic split cast iron top ring grates
- 26,000 Btuh/7.61 kW 2 piece cast iron Starfire- Pro open top burner
- 24" (610mm) raised griddle/broiler section W/ 3 cast iron burners each rated 11,000 Btuh/3.22 kW, w/one manual hi/lo valve per burner
- 5/8" (15mm) thick steel griddle plate, 23" (584mm) working depth surface
- 4-1/4" 108(mm) wide grease trough
- 38,000 Btuh/ 11.13 kW cast iron "H" style oven burner
- Snap action modulating oven thermostat low to 500° F
- Nickel plated oven rack and 3-position removable oven rack guide

- Large porcelain oven interior, fits standardize sheet pans in both directions for standard ovens
- Strong, keep-cool oven door handle
- Convection oven, for spark ignition models only (GFE), w/3 nickel plated oven racks and removable rack guides in lieu of standard oven w/ 1/3HP 120v 60 Hz single phase fan motor; change suffix RS to CS or RR to CR (1) or CC (2) convection ovens
- Cabinet base in lieu of oven

Optional Features:

- Convection oven motor 240v 50/60HZ single phase
- Hot top 12" (305mm) plate in lieu of two open burners, manual valve controlled w/18,000 Btuh/5.27 kW cast iron "H" burner standard on left side
- Stainless steel backguard, w/removable stainless shelf
- Stainless steel back panels for backguards or range
- Additional oven racks
- 6" (152mm) levelling swivel casters (4), w/front locking
- Flanged deck mount legs
- Stainless steel doors for storage base models
- Intermediate stainless steel shelf for storage base models
- Celsius temperature dials

Specifications:

Gas restaurant series range with large capacity (standard) oven. 59 1/16" (1500mm) wide and 27 1/4" (686mm) deep work top surfaces. Total flame failure protection for all burners. Stainless steel front, sides and 5" (127mm) wide front rail. 6" (152mm) legs with adjustable feet. Six Starfire-Pro 2 piece, 26,000 Btuh/7.61 kW, cast open burners set in split cast iron ergonomic grates. Hot top with cast iron "H" style burners 18,000 Btuh/527 kW . Porcelain oven interior with ribbed oven bottom and door. "Keep cool" oven door handle. Heavy cast iron "H" 38,000 Btuh/11.13 kW (natural gas) oven burner controlled by

even bake, fast recovery snap action modulating oven thermostat. Available with convection oven(s) (spark ignition models only) or storage base in lieu of standard oven.



Garland Commercial Industries, LLC
 185 East South Street
 Freeland, PA 18224
 Phone: (570) 636-1000
 Fax: (570) 636-3903

Garland Commercial Ranges Ltd
 1177 Kamato Road,
 Mississauga, Ontario
 L4W 1X4 CANADA
 Phone: 905-624-0260
 Fax: 905-624-5669



Model Number	Description	Total BTU/Hr Natural	Shipping Information	
			Lbs./Kg	Cu Ft
GF60-6R24RR	6 Open Burners, 24" Raised Griddle/Broiler w/ (2) Std. Ovens	265,000	828/376	81
GFE 60-6R24RR ¹	6 Open Burners, 24" Raised Griddle/Broiler w/ (2) Std. Ovens, Elec. Spark Ignition	265,000	828/376	81
GF60-6R24RS	6 Open Burners, 24" Raised Griddle/Broiler w/ (1) Std. Oven & (1) SB ²	227,000	787/357	81
GFE 60-6R24RS ¹	6 Open Burners, 24" Raised Griddle/Broiler w/ (1) Std. Oven & (1) SB ² , Elec. Spark Ignition	227,000	787/357	81

¹ Available with convection oven change RS to CS or RR to RC (1) or CC (2) convection ovens, GFE models only ²SB=Storage base

Width In (mm)	Depth ³ In (mm)	Height w/LPBG ⁵ In (mm)	Oven Interior-In (mm)			Storage Base Interior - In (mm)			Combustible Wall Clearance-In (mm)		Entry Clearances In (mm)	
			Height	Depth ⁵	Width	Height	Depth	Width	Sides	Rear	Crated	Uncrated
59 (1500)	34-1/2 (876)	47 (1194)	13 (330)	26 (660)	26-1/4 (667)	18-1/4 (464)	26-3/8 (670)	26-3/16 (655)	14 (3565)	6 (152)	37 (940)	36-1/2 (927)

³ Convection oven base models add 3 7/8" (98mm) to the depth of the unit. ⁴ LPBG = Low Profile Backguard

⁵ Convection oven depth 22" (559mm)

Gas Type	Burner Ratings (BTU/Hr/kW)				Manifold Operating Pressure
	Open Top	Hot Top	Standard Oven or Convection	Raised Griddle/Broiler	
Natural	26,000/7.61	18,000/5.27	38,000/11.13	33,000/9.66	4.5" WC, 11 mbar
Propane	26,000/7.61	18,000/5.27	32,000/9.38	33,000/9.66	10.0" WC, 25 mbar

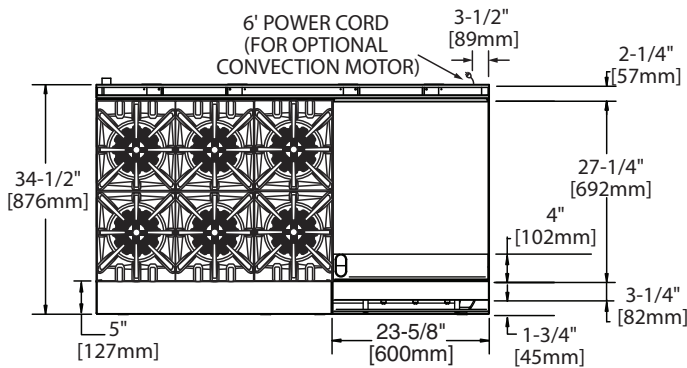

This product is not approved for residential use.

Gas input ratings shown for installations up to 2000 ft.,(610m) above sea level. Please specify altitudes over 2000 ft.

All 115V, 60Hz, 1 phase GFE models are supplied with a 6' (1829mm) cord and plug (NEMA-5-15P), 240V 50/60 Hz. 1 phase, 1.8 amps are not supplied with cord and plug and must be direct connect. Convection oven models draw 3.5 amps, standard GFE models draw 0.2 amps for the ignition system; 240V systems without the convection motor are 0.1 amps.

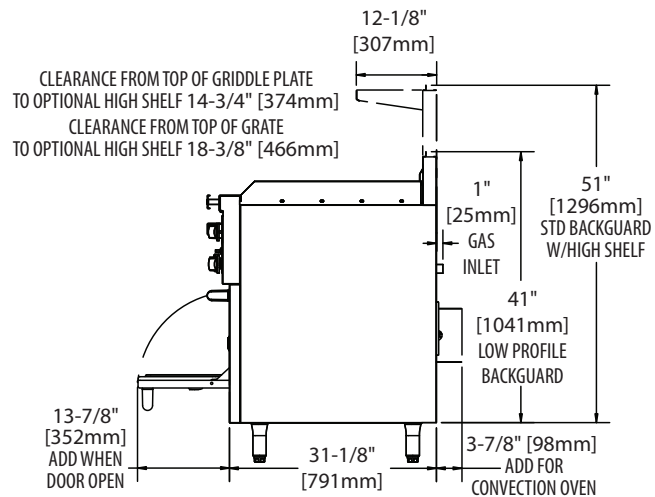
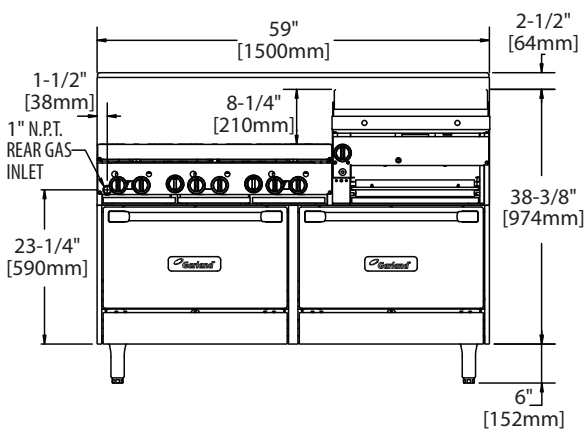

Form# 60"RG GF Series (10/07/09)