



# Cuisine Series Heavy Duty Combination Top Range

Item: \_\_\_\_\_  
 Quantity: \_\_\_\_\_  
 Project: \_\_\_\_\_  
 Approval: \_\_\_\_\_  
 Date: \_\_\_\_\_

Cuisine Series Heavy Duty Combination Top Range

Models:

- C836-14     C0836-14     C0836-14M     C836-14L     C0836-14L     C0836-14LM

Range with 2 Open burners & 18" Even Heat Hot Top



*Model C386-14*

Note: Range-based convection oven models can be located in the middle of a battery, banked back-to-back with other equipment, and can be positioned against a wall

### Standard Features:

- 18" (457mm) even heat hot top section, 32,500 BTUs
- Open Top burners 30,000 BTU each
- Full-range burner valve control
- One-piece cast iron top grates
- Stainless steel front and sides
- Stainless steel front rail w/ position adjustable bar
- 1-1/4" NPT front gas manifold
- Can be connected individually or in a battery
- 6" (152mm) H stainless steel stub back
- 6" (152mm) chrome steel adj. legs
- Stainless steel oven interior w/ removable porcelain bottom
- 40,000 BTU oven burner
- Chrome plated rack with four positions, 1 per oven
- Fully insulated oven interior
- 100% safety oven pilot
- Oven thermostat control control - 150°-500°F (66°-260°C)

### Optional Features:

- Stainless steel back
- Range base convection oven (add RC)
- Porcelain oven interior in lieu of

stainless steel interior – NC

- Single or double deck high shelf or back riser
- Modular unit with legs and shelf (suffix M)
- Modular unit w/o legs on Refrig. Base (change suffix M to PC)
- Stainless steel intermediate shelf for cabinet base
- Stainless steel door(s) for cabinet base units
- Continuous plate shelf, 48-72" for battery installations
- Gas shut-off valves – 3/4", 1", 1 1/4" NPT (Specify)
- Gas regulators 3/4" – 1/14" NPT (Specify)
- Gas flex hose w/ quick disconnect 3/4", 1", 1 1/4" (Specify)
- Stainless steel legs (set of four)
- Flanged feet set of four
- Swivel casters (4) w/ front locking
- Casters w/ polyurethane wheels – non marking
- Extra oven rack
- Rear Gas Connection; 3/4" NPT (max 250,000 BTU's) or 1-1/4" NPT
- Stainless steel burner box top interior

### Specifications:

U.S. Range Cuisine 36" (914mm) wide Heavy Duty Range Series. Model \_\_\_\_\_ with total BTU/hr rating of \_\_\_\_\_ when used with natural/propane gas. Stainless steel front and sides. 6" (152mm) legs with adjustable feet.

**Ovens** - One piece oven door. Stainless steel oven interior with a heavy-duty, "keep-cool" door handle. Standard oven comes with a thermostat with a temperature range from 150° (low) to 500°F (66°-260°C). One chrome plated oven rack for standard ovens and three for convection ovens.

**Open Burners** - 30,000 BTU/hr per burner with center pilot and a one piece, cast iron top grate over two open burners.

**18" (457mm) Section Even Heat Hot Tops** - 32,500 BTU/hr each burner with one per plate.



NOTE: Ranges supplied with casters must be installed with an approved restraining device.



Model #	Description	Total BTU (NAT. Gas)
C836-14*	(1) EHHT(Right) & (2) Open Burners - Standard Oven	132,500
C0836-14	(1) EHHT(Right) & (2) Open Burners - Cabinet	92,500
C0836-14M	(1) EHHT(Right) & (2) Open Burners - Modular	92,500
C386-14L	(1) EHHT(Left) & (2) Open Burners - Standard Oven	132,500
C0836-14L	(1) EHHT(Left) & (2) Open Burners - Cabinet	92,500
C0836-14LM	(1) EHHT(Left) & (2) Open Burners - Modular	92,500

Individual Burner Ratings (BTU/hr)		
Burner	NAT.	Pro.
Open Burner	30,000	28,000
18" Hot Top	32,500	32,500
Std. Oven	40,000	35,000
Conv. Oven	37,000	35,000

EHHT = Even Heat Hot Top

\* Add Suffix "RC" for Convection Oven Base

Model C836-14

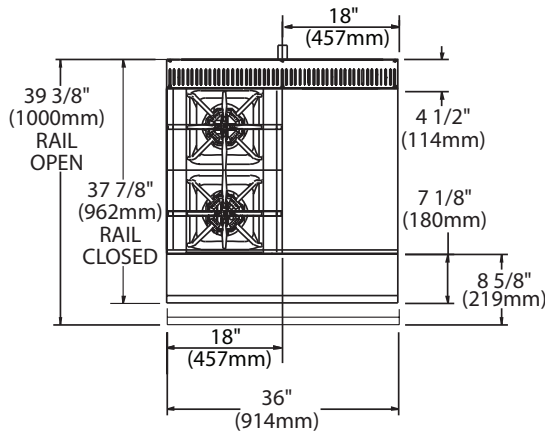

Interior Dimensions: In (mm)			
Product	Height	Width	Depth
Standard Oven	13-1/2(323)	26-1/4 (667)	29 (737)
Convection Oven	13-1/2(323)	26-1/4 (667)	25 (635)
Cabinet Base	20-1/2 (521)	32-1/4 (819)	31 (787)

Gas Pressure	NAT.	PRO.
Minimum Supply	7" WC	11" WC
Manifold Operating Pressure	6" WC	10" WC

Gas Manifold 1-1/4" NPT

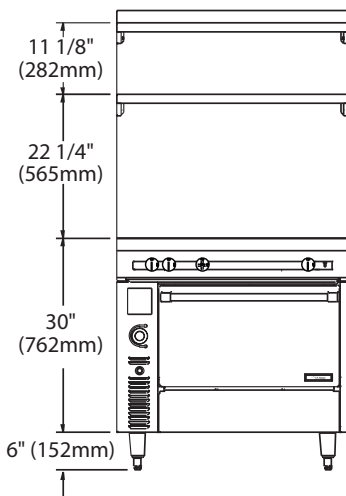
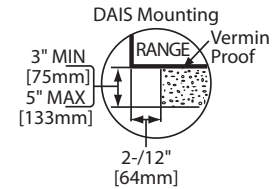
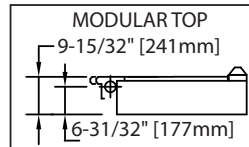

Model C336-14L

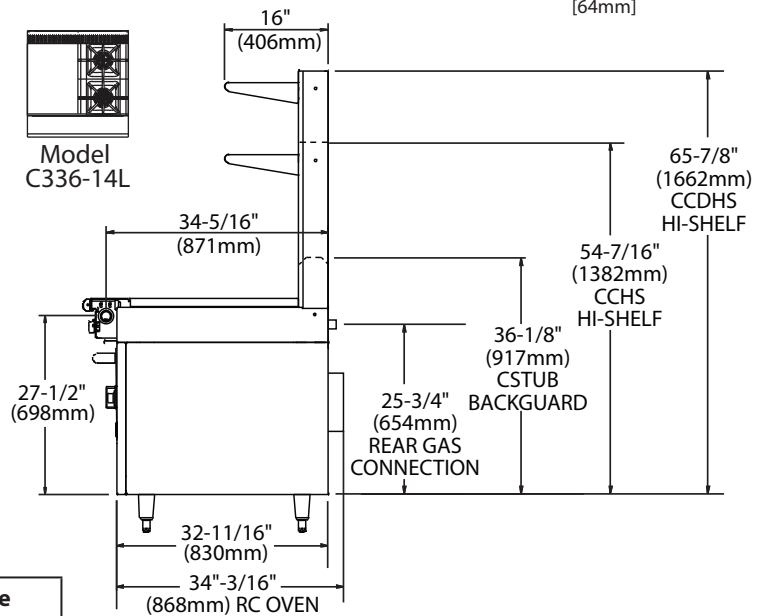

Combustible Wall Clearance	
Sides	Back
6" (152mm)	6" (152mm)

Form# C836-14 (08/16/11)