



# Cuisine Series Heavy Duty Range Match Filter System

Item: C836-FMA

Quantity: \_\_\_\_\_

Project: \_\_\_\_\_

Approval: \_\_\_\_\_

Date: \_\_\_\_\_

Models:

C836-FMA

## Range Match Fryer Filter System



*Model C836-FMA  
Shown with optional heat lamp*

### Standard Features:

- Stainless steel front rail, available in three positions 7-1/8" (181mm), 8" (203mm) and 8-1/2" (216mm)
- 6" (152mm) stainless steel stub back
- Stainless steel front and sides
- Stainless steel 12"x20"x2-1/2" stainless steel food pan
- Stainless steel wire rack screen
- Start up kit of filter paper and powder
- 6" (152mm) adjustable legs
- Filters up to six (6) model C836-1-35F fryers (Maximum three (3) on either side of filter)
- 1-1/4" front gas manifold

### Optional Features:

- Stainless steel main back
  - Solid work top in lieu of food pan
  - Extra filter powder, available as service part
  - Extra filter paper, available as service part
  - 3/4" or 1-1/4" NPT rear gas connection
  - Heat lamp for dump station, 115V/ 8 amps/500 watt
  - 6" (152mm) stainless steel legs
  - 6" (152mm) high polyurethane wheels
  - Swivel casters w/front brake
- NOTE: Systems supplied with casters must be installed with an approved restraining device.

### Specifications:

Range match filter system Model C836-FMA, 18" (457mm) wide spreader cabinet with built in oil pump system, which pulls out for easy cleaning. Standard with 12"x20"x2-1/2" stainless steel food pan and wire rack screen, pan fits into cut top of the spreader. Solid work top available in lieu of unit with food pan. One unit will supply up to (6) model C836-1-35F fryers (maximum 3 per side). Optional heat lamp available.



Cuisine Series Heavy Duty Range Match Filter System

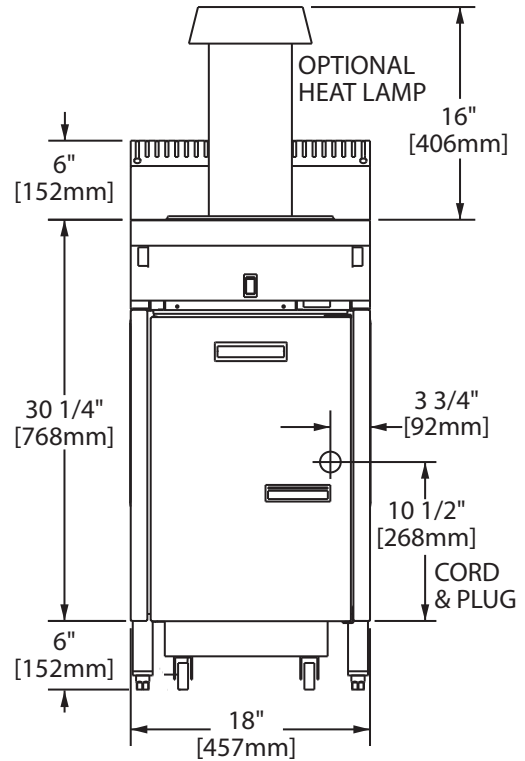
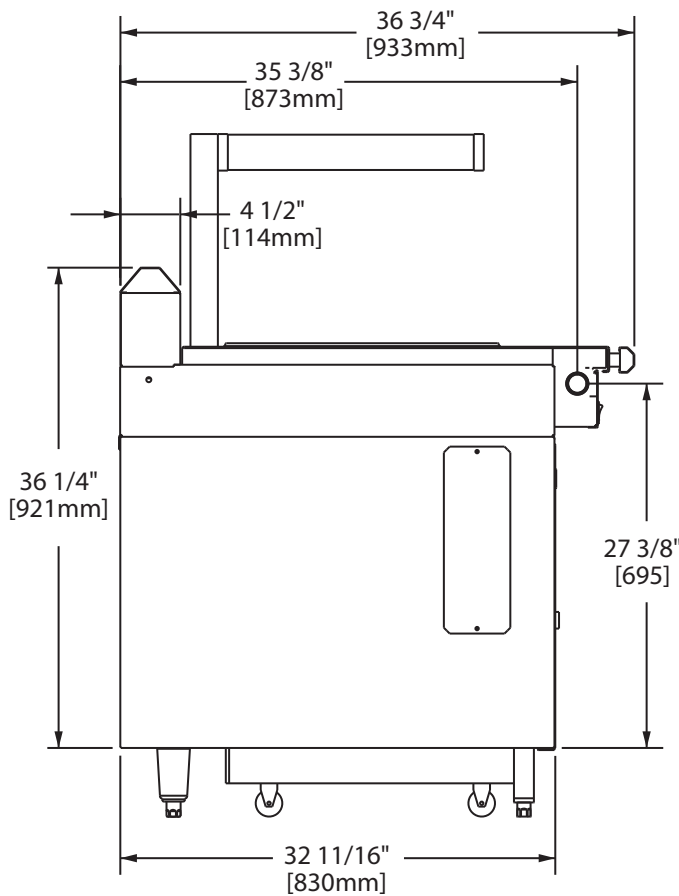

CLEARANCES				SHIPPING	
INSTALLATION		ENTRY		Cu Ft	Weight Lbs/Kg
Sides	Rear	Crated	Uncrated		
6" (152mm)	6" (152mm)	29-1/4" (743mm)	18-1/4" (464mm)	26	190/83 kg

Electrical characteristics  
 120 VAC 8 Amps  
 Export: 230 VAC, 50Hz, hard wire connection; cord and plug not supplied.

One C836-FMA unit will support up to (6) six model C836-1-35F fryers in a battery, (max. 3 per side), as illustrated in the diagram at right.

When ordering please provide description of desired battery line-up.

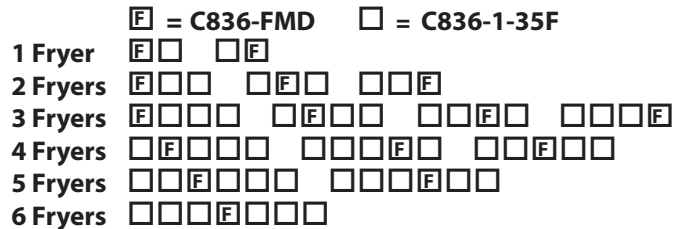

Garland/U.S. Range products are not approved or authorized for home or residential use, but are intended for commercial applications only. Garland / U.S. Range will not provide service, warranty, maintenance or support of any kind other than in commercial applications.

Form# C836-FMA (08/17/11)